

# Compact pressure switch, flameproof enclosure Ex d For the process industry Model PCA

WIKA data sheet PV 33.31



for further approvals  
see page 5

## Process Compact Series

### Applications

- Pressure monitoring and control of processes
- Safety-critical applications in general process instrumentation, especially in the chemical and petrochemical industries, oil and gas industries, power generation incl. nuclear power plants, water/wastewater industries, mining
- For gaseous and liquid, aggressive, highly viscous or contaminated media, also in aggressive environments
- For measuring locations with limited space, e.g. control panels

### Special features

- No supply voltage needed for the switching of electrical loads
- Robust switch enclosure from aluminium alloy or stainless steel with identical dimensions, IP66, NEMA 4X
- Setting ranges from 0.2 ... 1.2 to 200 ... 1,000 bar, vacuum ranges
- Repeatability of the set point  $\leq 1\%$  of span
- 1 set point, SPDT or DPDT, high switching power up to AC 250 V, 15 A



Model PCA, compact pressure switch

### Description

The pressure switches have been developed especially for safety-critical applications with limited space. The high quality of the products and manufacturing in accordance with ISO 9001 ensure reliable monitoring of your plant. In production, the switches are traced by quality assurance software at every step and subsequently are 100 % tested.

The robust switch enclosure from aluminium alloy or stainless steel 316 can withstand the rough and corrosive operating conditions of the process industry with working ranges of up to 1,000 bar. To adjust the set point simply open the access cover plate. The access to the terminal block for the electrical connection is protected by a screw-on lid, which is secured with a screw-type lock against unauthorised intervention.

A micro switch integrated in the instrument enables the direct switching of an electrical load of up to AC 250 V, 15 A.

Depending on the application, the appropriate variant for the contact version and the electrical connection can be selected; e.g., hermetically sealed micro switches are suitable for corrosive ambient conditions and DPDT contact versions for two separate circuits.

By using a diaphragm element with antagonist spring as sensor element, the model PCA pressure switch is extremely robust and guarantees optimal operating characteristics. For safety applications, the pressure switch is optionally available in a SIL 2 qualified or a SIL 3 qualified version.

# Specifications

Model PCA	
<b>Version</b>	Compact pressure switch <ul style="list-style-type: none"> <li>■ Oxygen version (cleaned for oxygen service)</li> <li>■ Version with drying of wetted parts</li> <li>■ NACE-compliant version per MR 0175, ISO 15156 and MR 0103 <sup>1)</sup></li> <li>■ Version compliant with EN 1854, pressure sensing devices for gas burners and gas burning appliances</li> <li>■ Offshore version</li> <li>■ Tropical version (suitable for environments with increased air humidity)</li> <li>■ Version for ammonia applications</li> <li>■ Geothermal version</li> </ul>
<b>Set point repeatability</b>	≤ 1 % of end of setting range
<b>Setting range/working range</b>	See table on page 4
<b>Ignition protection type <sup>2)</sup></b>	<ul style="list-style-type: none"> <li>■ Ex db I Mb (mines)</li> <li>■ Ex db IIC T6/T4 <sup>3)</sup> Ga/Gb (gas)</li> <li>■ Ex tb IIIC T85/T135 <sup>3)</sup> Db IP66 (dust)</li> </ul>
<b>Contact version</b>	Micro switches with fixed dead band <ul style="list-style-type: none"> <li>■ 1 x SPDT (single pole double throw)</li> <li>■ 1 x DPDT (double pole double throw)</li> </ul> The DPDT function is realised with 2 simultaneously triggering SPDT micro switches. See table on page 3 for available contact versions.
<b>Electrical connection</b>	<ul style="list-style-type: none"> <li>■ Female thread ½ NPT</li> <li>■ Female thread M20 x 1.5</li> <li>■ Female thread ¾ NPT</li> <li>■ Cable gland non-armoured, nickel-plated brass</li> <li>■ Cable gland non-armoured, stainless steel (AISI 304)</li> <li>■ Cable gland armoured, nickel-plated brass</li> <li>■ Cable gland armoured, stainless steel (AISI 304)</li> </ul> For cable connections to the internal terminal block use wire cross-sections between 0.5 ... 1.5 mm <sup>2</sup> . For the grounding cable connection to the protective conductor use max. 2.5 mm <sup>2</sup> for the internal screw and max. 4 mm <sup>2</sup> for the external screw.
<b>Dielectric strength</b>	Safety class I (IEC 61298-2: 2008)
<b>Process connection</b>	<ul style="list-style-type: none"> <li>■ Female thread ¼ NPT</li> <li>■ Male thread ½ NPT, G ½ A, G ¼ A via adapter</li> <li>■ Female thread ½ NPT, G ¼ via adapter</li> </ul>
<b>Permissible temperature</b>	
Medium	Depending on sensor element and sealing, see tables on next page
Ambient	See operating instructions
<b>Switch enclosure</b>	<ul style="list-style-type: none"> <li>■ Aluminium alloy, copper-free, painted with polyurethane</li> <li>■ Stainless steel 316L</li> </ul> Tamper-proof due to access cover plate with lead seal option Laser-engraved product label from stainless steel.
<b>Wetted materials</b>	
Process connection	Stainless steel 316L, lower mount
Sensor element	See table on page 3
<b>Ingress protection per IEC/EN 60529</b>	IP66 (NEMA 4X)
<b>Weight</b>	<ul style="list-style-type: none"> <li>■ 0.8 kg, switch enclosure aluminium alloy</li> <li>■ 1.5 kg, switch enclosure stainless steel</li> </ul>
<b>Mounting</b>	<ul style="list-style-type: none"> <li>■ Direct mounting</li> <li>■ Wall mounting</li> <li>■ Mounting bracket for 2" pipe mounting</li> </ul> For mounting positions see drawing on page 6

1) WIKA recommends argon gas-filled contact versions

2) Ex db IIC T6/T4 Gb and Ex tb IIIC T85/T135 Db IP66 (version with sensor element "P")

3) The temperature class is related to the ambient temperature range. See operating instructions for further details.

Contact version		Electrical rating (resistive load)	
		AC	DC
<b>A</b>	1 x SPDT, silver	250 V, 15 A	24 V, 2 A, 125 V, 0.5 A, 220 V, 0.25 A
<b>B</b>	1 x SPDT, silver, hermetically sealed, argon gas filling <sup>1)</sup>	250 V, 15 A	24 V, 2 A, 220 V, 0.5 A
<b>C</b>	1 x SPDT, gold-plated, hermetically sealed, argon gas filling <sup>1)</sup>	125 V, 1 A	24 V, 0.5 A
<b>G</b>	1 x DPDT, silver	250 V, 5 A	24 V, 0.5 A
<b>H</b>	1 x DPDT, silver, hermetically sealed, air filling	250 V, 5 A	24 V, 0.5 A

1) Permissible ambient temperature range: -30 ... +70 °C

Sensor element		Wetted parts	Permissible medium temperature <sup>2)</sup>
<b>V</b>	Diaphragm element with antagonist spring	NBR	-30 ... +110 °C
<b>T</b>	Diaphragm element with antagonist spring	PTFE	-30 ... +110 °C
<b>M</b>	Diaphragm element with antagonist spring	Inconel®, O-ring FPM	-30 ... +200 °C
<b>P</b>	Piston with antagonist spring <sup>3)</sup>	<ul style="list-style-type: none"> <li>■ Stainless steel 316, O-ring FPM</li> <li>■ Stainless steel 316, O-ring NBR</li> </ul>	<ul style="list-style-type: none"> <li>■ 0 ... +200 °C</li> <li>■ -10 ... +110 °C</li> </ul>
<b>G</b>	Piston with antagonist spring and welded diaphragm element	Hastelloy® C276	-40 ... +140 °C

2) Permissible medium temperature range in the main process line. Depending on the measuring arrangement, this may differ from the permissible temperature at the process connection. For further information, see operating instructions.

3) Particularly suited for liquid media.

Setting range	Sensor element	Working range <sup>1)</sup>	Proof pressure <sup>2)</sup>	Max. dead band for contact version		
				A, B, C	G	H
in bar		in bar	in bar	in bar	in bar	in bar
-1 ... -0.2	V	-1 ... 6	10	0.03	0.06	0.12
0.1 ... 2.5	M	-1 ... 30	40	0.05	0.1	0.4
0.2 ... 1.2	T	0 ... 6	10	0.03	0.06	0.12
0.5 ... 2.5	M	-1 ... 10	40	0.05	0.1	0.4
0.8 ... 6	M	-1 ... 10	40	0.06	0.2	0.8
1.6 ... 10	M	-1 ... 25	40	0.2	0.4	1.6
3 ... 25	P, G	0 ... 250	400	2	4	16
3.5 ... 70	P, G	0 ... 140	500	7	7	21
4 ... 25	M	-1 ... 25	60	0.25	0.75	3
8 ... 40	P, G	0 ... 100	400	2	4	16
10 ... 40	M	-1 ... 60	100	1	2	8
16 ... 100	P, G	0 ... 250	400	5	5	20
20 ... 100	M	0 ... 100	150	7	9	20
20 ... 220	P, G	0 ... 350	500	8	15	24
40 ... 250	P, G	0 ... 400	600	12	20	80
60 ... 250	P, G	0 ... 400	600	5 ... 12 to 12 ... 20 <sup>3)</sup>	-	-
80 ... 400	P, G	0 ... 600	600	20	20	80
100 ... 600	P, G	0 ... 600	700	30	30	120
100 ... 700	P	0 ... 700	1,050	30 ... 100 <sup>3)</sup>		
200 ... 1,000	P	0 ... 1,000	1,500	40 ... 110 <sup>3)</sup>		

1) Pressure range that can be applied continuously without causing any damage or shifting the set point.

2) Maximum pressure that the sensor element can withstand without suffering any permanent damage. The instrument might have to be calibrated afterwards.

3) The dead band depends on the set point adjustment. The indicated ranges are valid for the start and end of the setting range.

Other setting ranges are proportional.

## Set point adjustment

The set point can be specified by the customer or factory-set within the setting range.

The switch point and the switching direction need to be specified (e.g. switch point: 2 bar, rising).

For optimal performance we suggest to adjust the set point between 25 ... 75 % of the setting range. In the following example, the maximum possible setting range is shown to be dependent upon the switching direction.

### Example





Setting range: 0.8 ... 6 bar with one switch contact

Dead band = 0.06 bar (see table "Setting ranges" for contact version: A, B, C)

Rising pressure: Set point can be adjusted between 0.86 ... 6 bar

Falling pressure: Set point can be adjusted between 0.8 ... 5.94 bar

## Approvals

Logo	Description	Country
	<b>EU declaration of conformity</b> <ul style="list-style-type: none"> <li>■ Pressure equipment directive</li> <li>■ Low voltage directive</li> <li>■ RoHS directive</li> <li>■ ATEX directive <sup>1)</sup> <ul style="list-style-type: none"> <li>I M2</li> <li>II 1/2 GD</li> <li>II 2 GD (version with sensor element "P")</li> </ul> </li> </ul>	European Union
	<b>IECEx <sup>1)</sup></b> <ul style="list-style-type: none"> <li>Ex db I Mb</li> <li>Ex db IIC T6/T4 <sup>2)</sup> Ga/Gb, Ex tb IIIC T85/T135 <sup>2)</sup> Db</li> <li>Ex db IIC T6/T4 <sup>2)</sup> Gb, Ex tb IIIC T85/T135 <sup>2)</sup> Db (version with sensor element "P")</li> </ul>	International
	<b>EAC (option)</b> <ul style="list-style-type: none"> <li>■ EMC directive</li> <li>■ Low voltage directive</li> <li>■ Hazardous areas <sup>1)</sup></li> </ul>	Eurasian Economic Community
	<b>KOSHA (option)</b> Hazardous areas <sup>1)</sup>	South Korea
-	<b>PESO</b> Hazardous areas <sup>1)</sup>	India

1) Double marking ATEX and IECEx on the same product label.

2) The temperature class is related to the ambient temperature range.

## Manufacturer's information and certificates

Logo	Description
	<b>SIL 2 or SIL 3</b> Functional safety

## Certificates (option)

- 2.2 test report per EN 10204
- 3.1 inspection certificate per EN 10204

Approvals and certificates, see website

## Accessories

- Wall bracket from stainless steel
- Mounting bracket for 2" pipe mounting
- Shut-off valve; model 910.11; see data sheet AC 09.02
- Needle valve and multiport valve; models IV10, IV11; see data sheet AC 09.22
- Block-and-bleed valve; models IV20, IV21; see data sheet AC 09.19
- Diaphragm seals, see website

## Dimensions in mm

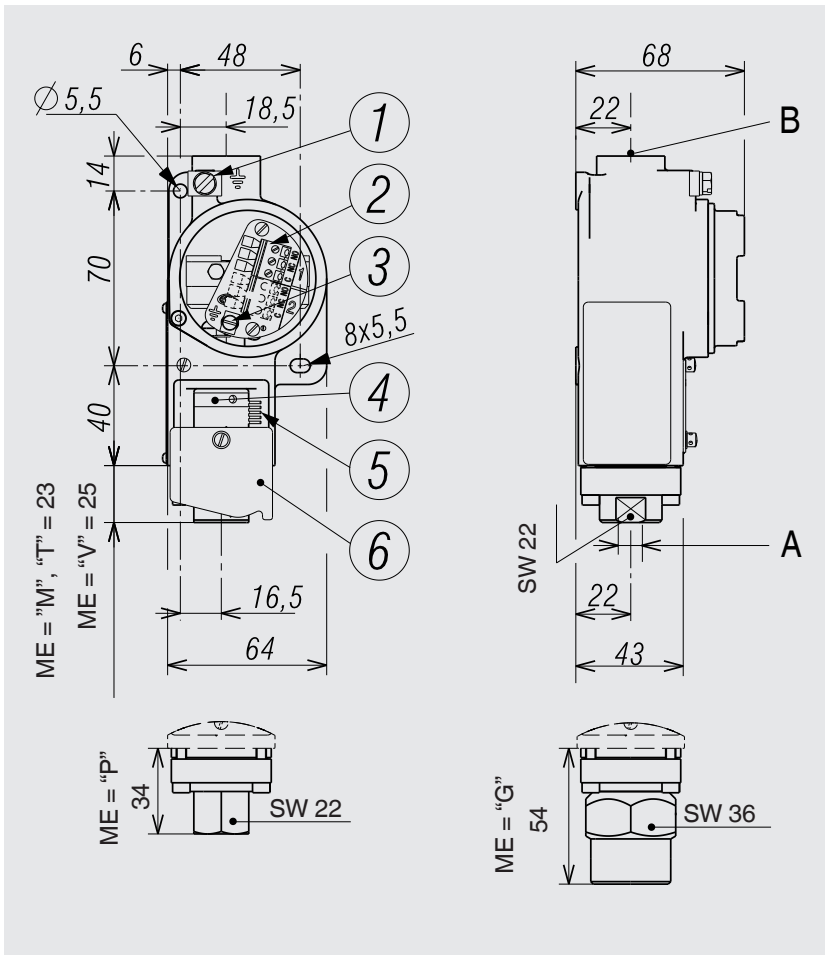

## Legend

- ① Ground screw, outside
- ② Terminal block
- ③ Ground screw, inside
- ④ Adjustment bushing
- ⑤ Calibration scale
- ⑥ Access cover plate
- A Process connection
- B Electrical connection
- ME Sensor element, see table on page 3
- SW Spanner width

## Permissible mounting positions

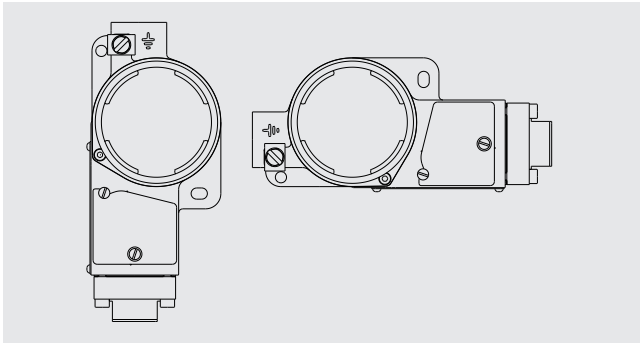

## With affixed lead seal

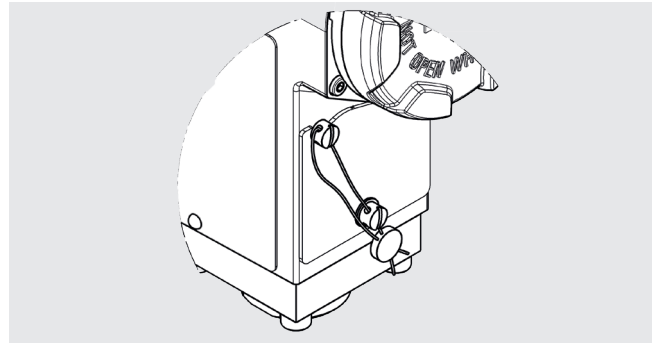

## Ordering information

Model / Unit / Setting range of set point / Contact version / Process connection / Electrical connection / Wetted parts / Options

© 12/2010 WIKA Alexander Wiegand SE & Co. KG, all rights reserved.  
The specifications given in this document represent the state of engineering at the time of publishing.  
We reserve the right to make modifications to the specifications and materials.

